

Solid State SEM Detectors

BSE – Annular BSE – STEM – Annular STEM - HAADF

The Deben Solid state SEM detector is modular, at the heart of the system is an **ARM2** mechanical interface with **Gen5** electronics, and software GUI. **ARM2** can be adapted to most conventional SEMs having a free chamber port at 90° to the beam axis. **Gen5** electronics can be supplied in standalone or 19" rack format with a standalone preamplifier positioned on the SEM plinth. Control of diode segments and brightness/contrast is from a GUI running under Windows® 7.0/10.0, 32/64 bit. Up to three simultaneous channels of video are fed back to the SEM for viewing and saving. Depending on applications, different diodes may be used on the same **ARM2/Gen5** system for BSE or STEM imaging.

- Exchangeable BSE & STEM diodes
- High speed
- Excellent low kV performance
- High sensitivity

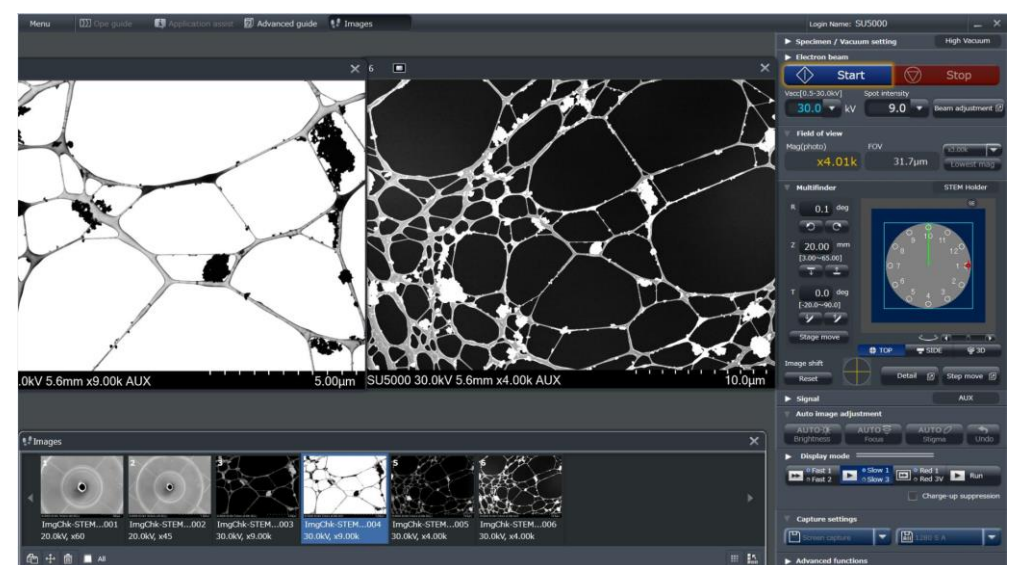
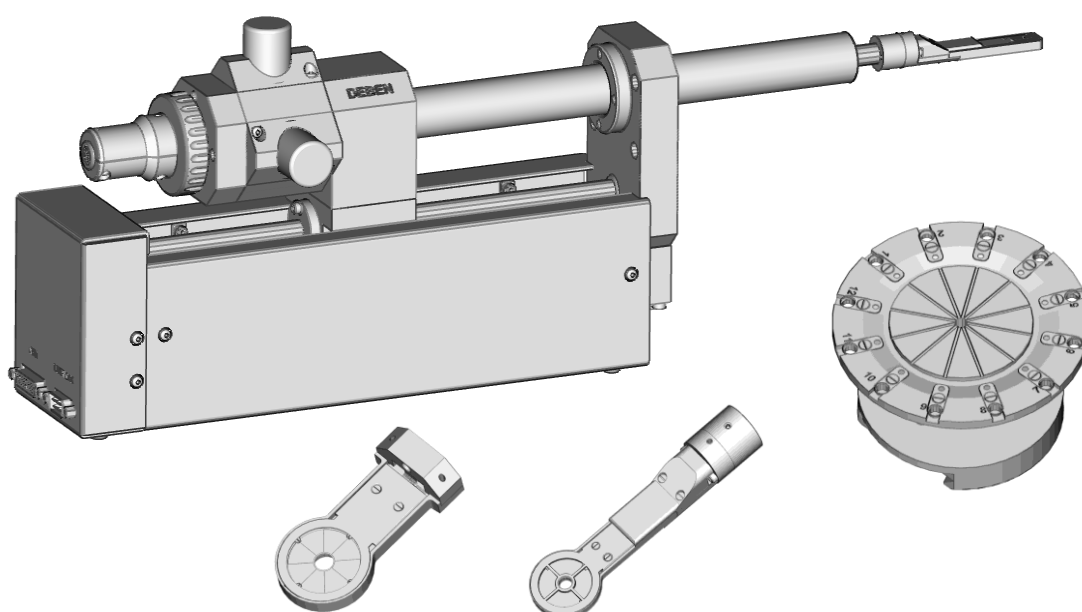
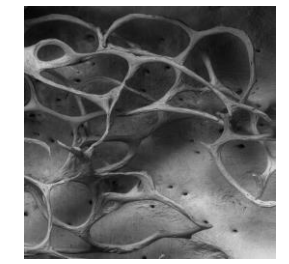
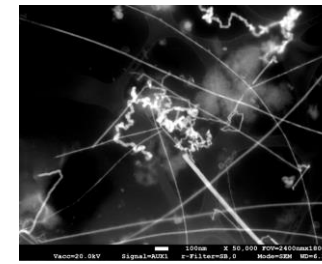
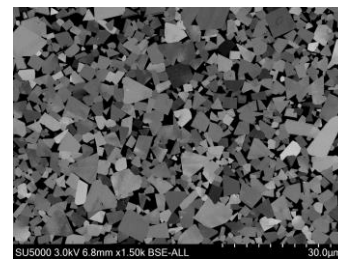
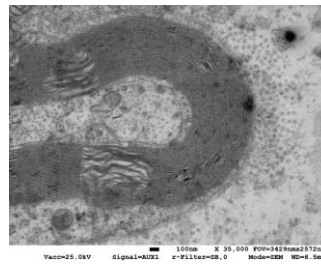
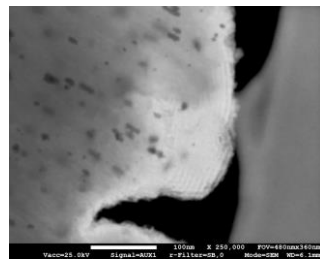
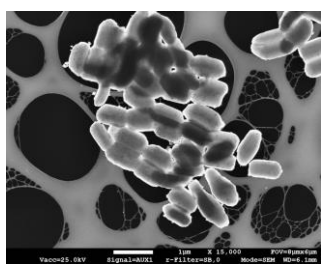

All diodes are made from the same Ultra Low kV PN silicon and are gridded to reduce surface charge build up. There are four input channels and each input can be switched on/off or inverted.

Any combination of inputs can be mixed to provide the signal output. This means you can run in full or selected area Compositional mode, angular Topographic mode, or phase contrast modes giving a high level of flexibility for the operator.

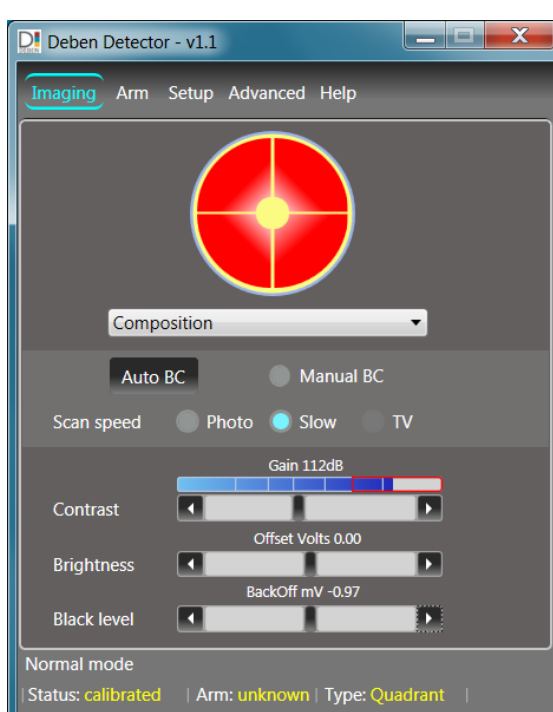

Specifications

- Motorised ARM2 mechanics suitable for most conventional SEMs
- Exchangeable diodes, different BSE and STEM options
- 12 position 3.05mm grid holder with mountings to suit SEM stage
- 4 simultaneous input channels
- Aux video input required on SEM for image display and saving
- 8,000,000:1 total gain range, auto control system with imaging to TV rate
- Gen5 amplifier system, standalone or 19" rack option
- One or three (optional) simultaneous analogue video outputs
- Easy to use GUI compatible with Windows® 7.0/10.0, 32/64bit
- Operating voltage 115V/230V 100VA, fully CE and RoHS compliant

Standard BSE Detector diodes

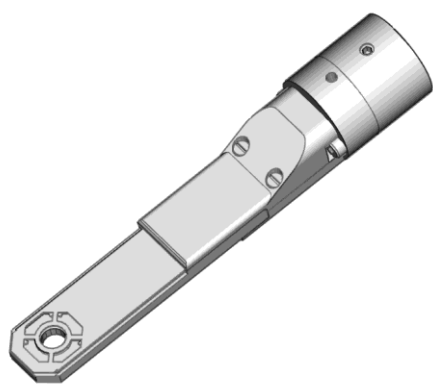

Field of view: 5.9mm
Diameter: 10mm



1.2mm
14mm



5.9mm
18mm



5.9mm
24mm

There are four standard BSE diodes available. Diodes are user interchangeable so it's possible to purchase more than one diode and for the user to interchange as required depending on application.

10mm is our smallest diode with the smallest detection area offering a wide field of view and compatibility with high angle EDX detectors. **14mm** offers a small hole which limits the lowest magnification but provides good collection of low angle BS electrons, compatible with medium angle EDX detectors. **18mm** is our standard BSE diode but not compatible with most EDX detectors for simultaneous BSE and EDX. **24mm** is a large diode with high sensitivity specifically for high angle BS electrons.

Standard STEM Detector diodes



4 Element DF
& BF STEM



Full Annular LAADF, MAADF
HAADF & BF



Four quadrant Annular DF, HAADF
& BF

We offer three standard STEM diodes for different applications. **4 Element DF** provides entry level STEM functionality and is suitable for Life Science applications. **Full Annular** is suitable for Life Science and Materials Science applications providing BF, DF & HAADF imaging. **Four Quadrant Annular** is suitable for Materials Science applications and allows the user to display angular DF or HAADF images by selecting HAADF segments in phase contrast mode.

Specialist BSE & STEM diodes

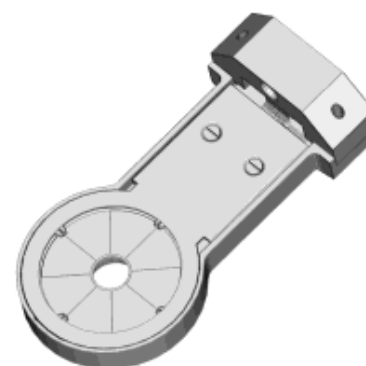
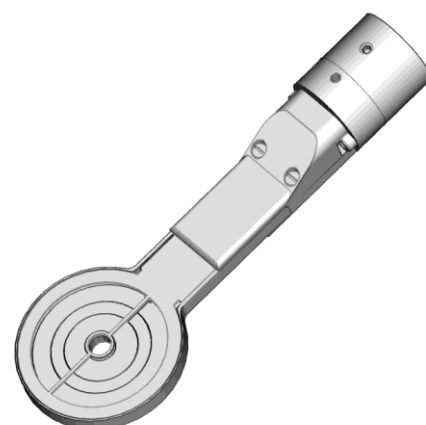

More specialist diodes are available for specific applications such as a 26mm diameter full annular BSE diode and an 8 segment HAADF diode as shown above. We also custom manufacture diodes for specific OEM applications